

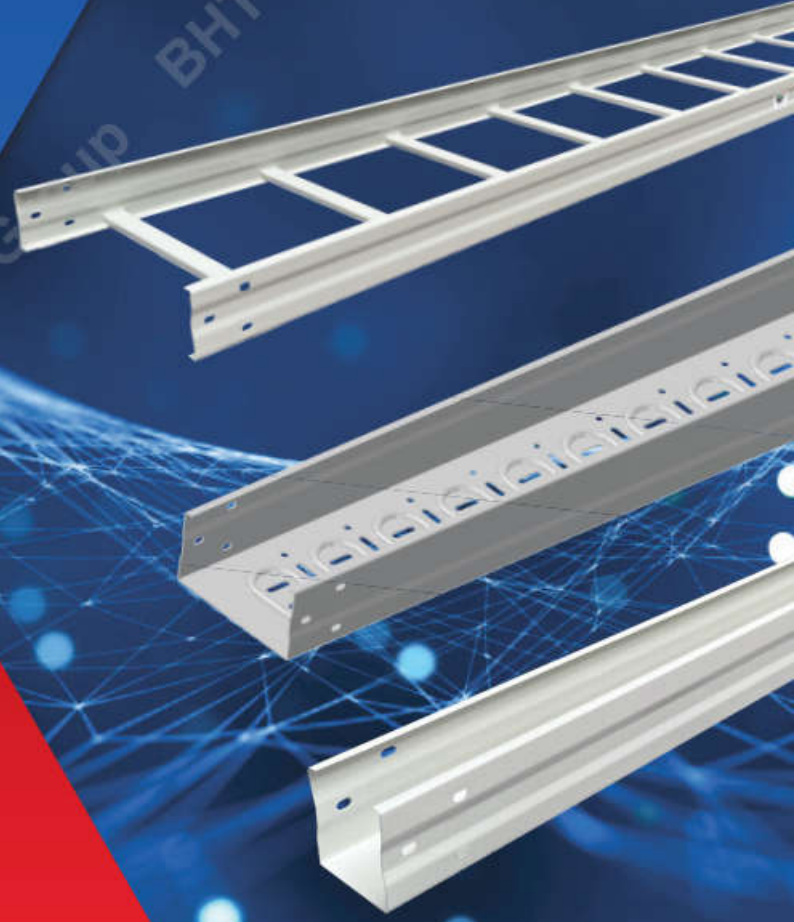

CATALOGUE

THANG MÁNG CÁP

Cable Ladder - Cable Tray - Cable Trunking

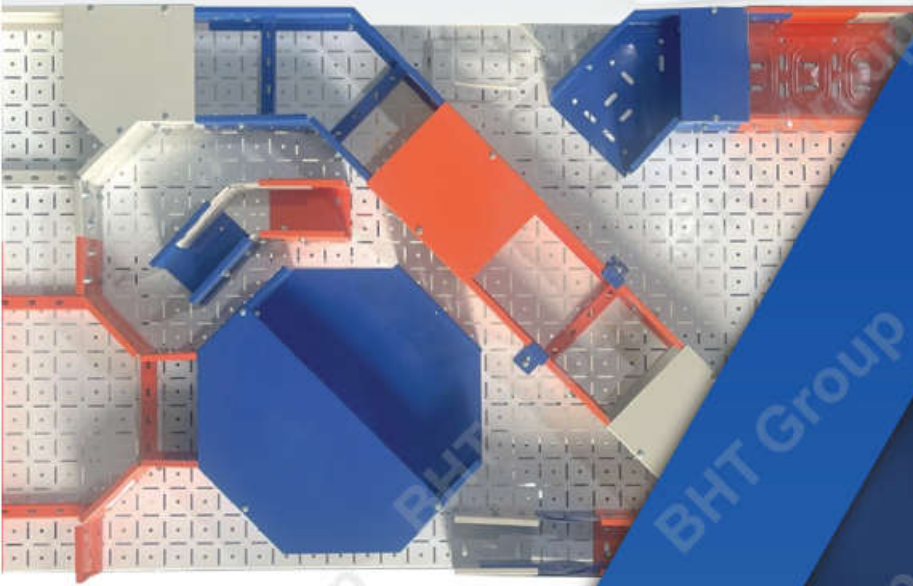

VỀ CHÚNG TÔI

About Us

BHT Group nhà sản xuất hàng đầu trong lĩnh vực thang máng cáp, với hơn 21 năm kinh nghiệm và uy tín vững chắc trong ngành công nghiệp sản xuất thiết bị điện, thiết bị lưới điện và viễn thông, thiết bị công trình giao thông, kết cấu thép. Chúng tôi cam kết cung cấp các sản phẩm chất lượng cao, đáp ứng các tiêu chuẩn quốc tế, đảm bảo độ an toàn và độ bền vượt trội cho các công trình.

BHT Group không ngừng tiên phong ứng dụng công nghệ tự động và quy trình sản xuất khép kín, nhằm tối ưu hóa thời gian sản xuất, tiết kiệm chi phí và nâng cao hiệu suất. Chúng tôi mang đến những giải pháp toàn diện, đáp ứng nhu cầu của khách hàng và đối tác trong các dự án quy mô lớn.

BHT Group is a leading manufacturer in the field of cable tray systems, with over 21 years of experience & solid reputation in the electrical equipment manufacturing industry, power grid & telecommunications equipment, traffic safety equipment, steel structure. We are committed to providing high-quality products that meet international standards, ensuring superior safety and durability for various projects.

BHT Group continuously pioneers in the application of automation technology & a closed-loop production process to optimize production time, reduce costs, and enhance efficiency. We offer comprehensive solutions that meet the needs of our clients and partners in large-scale projects.



Nhà Máy BHT Bình Dương
BHT Binh Duong Factory



Nhà Máy BHT Hóa An
BHT Hoa An Factory



Nhà Máy BHT Đà Nẵng
BHT Da Nang Factory



Nhà Máy BHT Nam Hà
BHT Nam Ha Factory

MỤC LỤC

Table Of Contents

01

CÔNG NGHỆ SẢN XUẤT & CHỨNG NHẬN

Production technology & Certification

- 1.1 Công nghệ & Quy trình sản xuất
Technology & Manufacturing process
- 1.2 Chứng nhận
Certification

02

SẢN PHẨM THANG CÁP

Cable ladder products

- 2.1 Thanh thẳng thang cáp
Cable ladder straight
- 2.2 Co thang cáp gân cạnh
Ribbed edges cable ladders
- 2.3 Co thang cáp không gân cạnh
Cable ladders without ribbed edges
- 2.4 Thông số kỹ thuật co thang cáp
Cable ladder technical specifications

03

SẢN PHẨM KHAY CÁP

Cable tray products

- 3.1 Thanh thẳng khay cáp
Cable tray straight
- 3.2 Co khay cáp gân cạnh
Ribbed edges cable tray
- 3.3 Co khay cáp không gân cạnh
Cable tray without ribbed edges
- 3.4 Thông số kỹ thuật co khay cáp
Cable tray technical specifications

04

SẢN PHẨM MÁNG CÁP

Cable trunking products

- 4.1 Thanh thẳng máng cáp
Cable trunking straight
- 4.2 Co máng cáp gân cạnh
Ribbed edges cable trunking
- 4.3 Co máng cáp không gân cạnh
Cable trunking without ribbed edges
- 4.4 Thông số kỹ thuật co máng cáp
Cable trunking technical specifications
- 4.5 Phụ kiện & tham khảo
Accessories & Explore more

QUY TRÌNH SẢN XUẤT THANG CẤP
Cable ladder manufacturing process

<p>1</p>  <p>Chuẩn bị nguyên liệu: Thép tấm, băng cuộn Prepare material: Steel plate, tape rolls</p>	<p>2</p>  <p>Quy trình cắt, cán rail, cán rung Cutting process, rail rolling, vibration rolling</p>	<p>3</p>  <p>Quy trình đột Punching process</p>
<p>4</p>  <p>Quy trình chấn hoặc cán biên dạng Bending or rolling profile process</p>	<p>5</p>  <p>Quy trình hàn Welding process</p>	<p>6</p>  <p>Vệ sinh công nghiệp Industrial hygiene</p>
<p>7</p>  <p>Quy trình sơn tĩnh điện/nhúng nóng Powder coating/hot dip process</p>		<p>8</p>  <p>Quy trình kiểm tra, đóng gói, xuất xưởng Process of checking, packing and shipping</p>

QUY TRÌNH SẢN XUẤT MÁNG CÁP
Cable tray manufacturing process

<p>1</p>  <p>Chuẩn bị nguyên liệu: Thép tấm, băng cuộn Prepare material: Steel plate, tape rolls</p>	<p>2</p>  <p>Đột lỗ, tạo gân, cán biên dạng và cắt Punching holes, creating ribs, rolling profiles and cutting</p> <p>HOẶC OR</p>  <p>Quy trình cắt/chấn Cutting/bending process</p>	
<p>3</p>  <p>Vệ sinh công nghiệp Industrial hygiene</p>	<p>4</p>  <p>Quy trình sơn tĩnh điện/nhúng nóng Powder coating/hot dip process</p> <p>5</p>  <p>Quy trình kiểm tra, đóng gói, xuất xưởng Process of checking, packing and shipping</p>	

1.2 CHỨNG NHẬN Certification



CHỨNG NHẬN HỢP CHUẨN - HỢP QUY Certificate of standard and regulation conformity



HỆ THỐNG QUẢN LÝ CHẤT LƯỢNG Quality management system

HỆ THỐNG QUẢN LÝ MÔI TRƯỜNG Environmental management system

2.1 THANH THẲNG THANG CÁP

Cable ladder straight

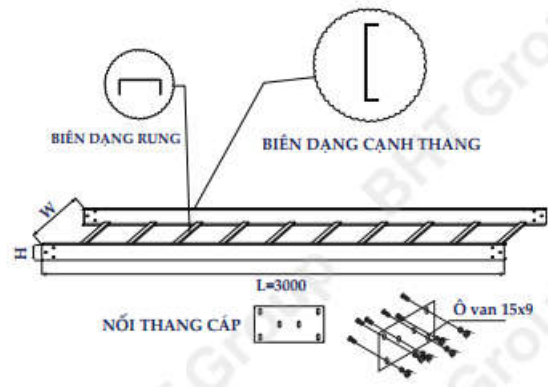
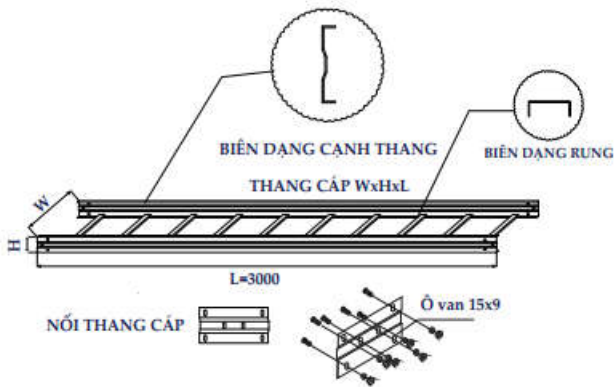

Tiêu chuẩn:

- + Có gân cạnh: H100
- + Không đường gân cho thang kẽm, inox, tole zam mà độ dày trên 2mm.

Loại đặc biệt:

- + Thanh rung có đục lỗ, thanh rung chắn C.

Standard:

- + With edge ribs: H100
- + No ribs for galvanized, stainless steel, or zam-coated trays with thickness over 2mm.

Special type:

- + Perforated vibrating bar, C-profile vibrating bar.

1. Vật liệu/Material

- Thép tấm tráng kẽm (JIS 3302).
- Thép tấm đen (cán nóng, cán nguội).
- Thép tấm không gỉ SS304, SS316.
- Pre galvanized steel sheet (JIS 3302).
- Mild steel sheet (hot rolled, cold rolled).
- Stainless steel sheet 304, 316.

2. Hoàn thiện sản phẩm/Finish

- Bề mặt tự nhiên của vật liệu đối với sản phẩm tôn tráng kẽm, thép không gỉ.
- Mạ nhúng nóng.
- Sơn tĩnh điện.
- Nature - protection for pre galvanized and stainless steel sheet.
- Hot dip galvanized - HDG.
- Power coated - PC

3. Độ dài tiêu chuẩn/Standard length

3.0m/thanh

3.0m/length

Tên hàng Item

Rộng x Cao x Dày W x H x T

L Cable ladder, light duty

1.0 thickness	50 x 50 x (1.0, 1.2)
1.2 thickness	75 x (50, 75) x (1.0, 1.2)
50mm high	100 x (50, 75, 100) x (1.0, 1.2)
75mm high	150 x (50, 75, 100) x (1.0, 1.2)
100mm high	200 x (50, 75, 100) x (1.0, 1.2)
	300 x (50, 75, 100) x (1.0, 1.2)

M Cable ladder, medium duty

	100 x (75, 100) x 1.5
	200 x (75, 100) x 1.5
1.5 thickness	300 x (75, 100) x 1.5
75mm high	400 x (75, 100) x 1.5
100mm high	500 x (75, 100) x 1.5
	600 x (75, 100) x 1.5
	700 x (75, 100) x 1.5
	800 x (75, 100) x 1.5

H Cable ladder, heavy duty

	200 x (75, 100, 125, 150) x 2.0
	300 x (75, 100, 125, 150) x 2.0
2.0 thickness	400 x (75, 100, 125, 150) x 2.0
75mm high	500 x (75, 100, 125, 150) x 2.0
100mm high	600 x (75, 100, 125, 150) x 2.0
125mm high	700 x (75, 100, 125, 150) x 2.0
150mm high	800 x (75, 100, 125, 150) x 2.0
	900 x (75, 100, 125, 150) x 2.0
	1000 x (75, 100, 125, 150) x 2.0

F Cable ladder, fittings

Bulong đầu dù cổ vuông - Mushroom head square neck bolt M8x12

Long dẹt - Flat washer M8

Con tán - Hex nut M8

Miếng nối thang cáp - Ladder connector

Note: Material thickness: 1, 1.2, 1.5, 2.0

Xin xác định vật liệu khi gửi yêu cầu/Please confirm material on your request

Tôn tráng kẽm
Pre galvanized steel

Mạ nhúng nóng - HDG
Hot dip galvanized - HDG

Sơn tĩnh điện - PC
Power coated - PC

Thép không gỉ
Stainless steel

2.2 CO THANG CÁP GÂN CẠNH

Ribbed edges cable ladders

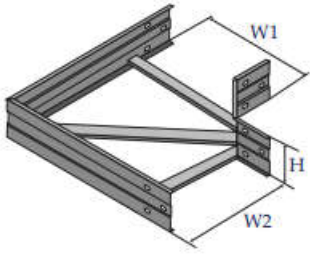

Co ngang 90°
Horizontal elbow 90°

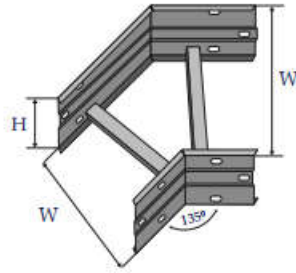

Co ngang 45°
Horizontal elbow 45°

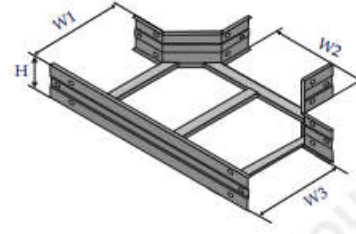

Co chữ T
Horizontal T

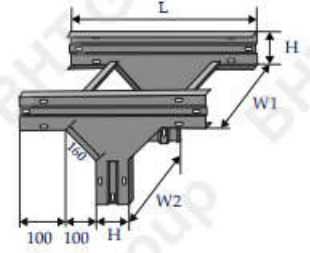

Co T đứng trực ngang
T shaped hinge horizontal

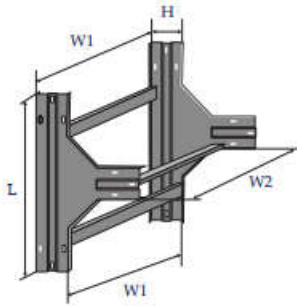

Co T đứng trực dọc
T shaped hinge vertical

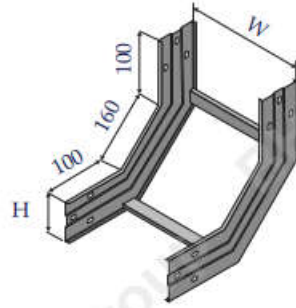

Co lên 90°
Internal riser 90°

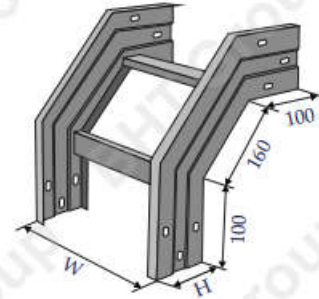

Co xuống 90°
External riser 90°

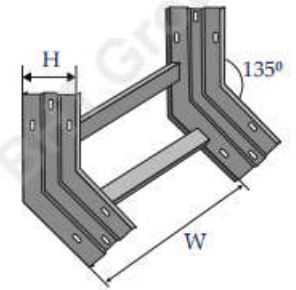

Co lên 45°
Internal riser 45°

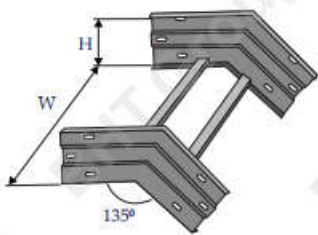

Co xuống 45°
External riser 45°

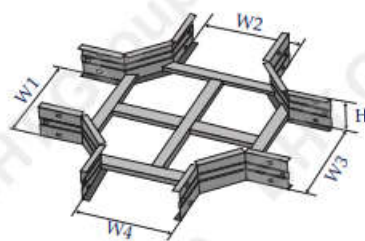

Co ngã tư
Horizontal cross

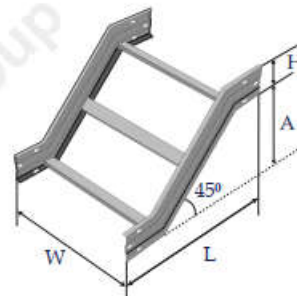

Co đứng Z
Vertical Z

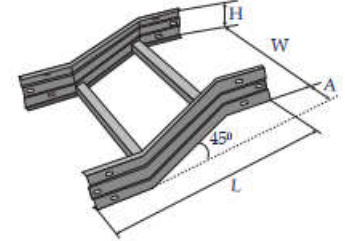

Co Z ngang phải
Right horizontal Z

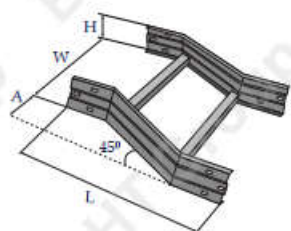

Co Z ngang trái
Left horizontal Z

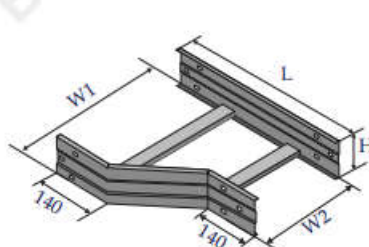

Co giảm phải
Right reducer

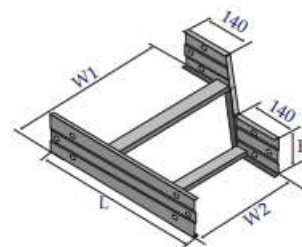

Co giảm trái
Left reducer

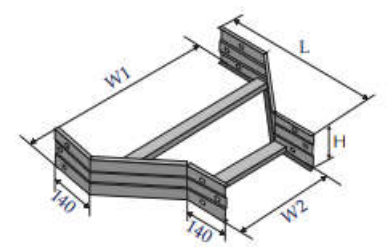

Co giảm giữa
Offset reducer

2.3 CO THANG CÁP KHÔNG GÂN CẠNH

Cable ladders without ribbed edges

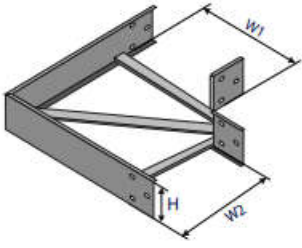

Co ngang 90°
Horizontal elbow 90°

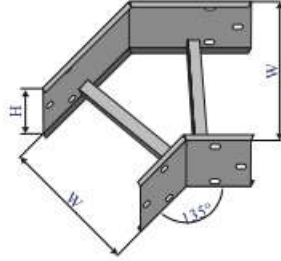

Co ngang 45°
Horizontal elbow 45°

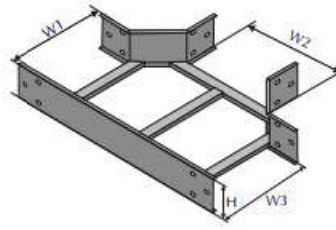

Co chữ T
Horizontal T

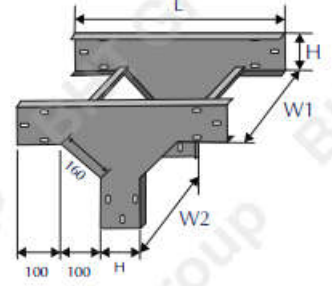

Co T đứng trục ngang
T shaped hinge horizontal

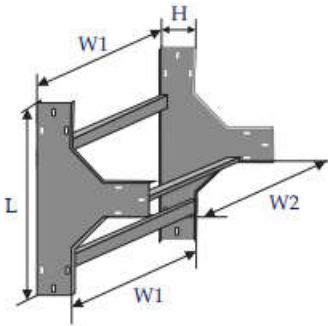

Co T đứng trục dọc
T shaped hinge vertical

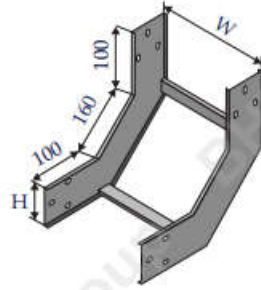

Co lên 90°
Internal riser 90°

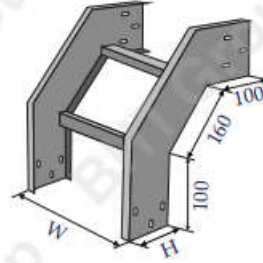

Co xuống 90°
External riser 90°

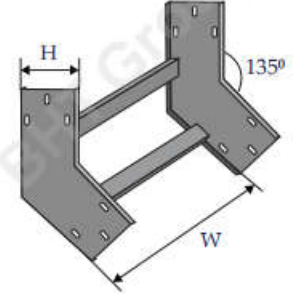

Co lên 45°
Internal riser 45°

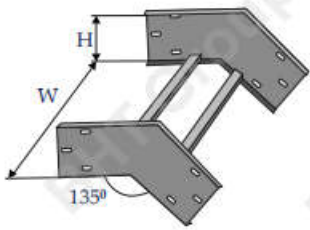

Co xuống 45°
External riser 45°

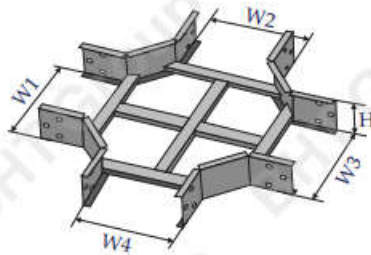

Co ngã tư
Horizontal cross

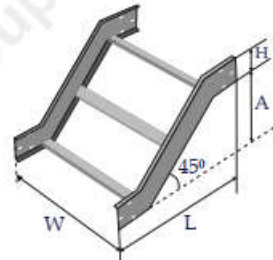

Co đứng Z
Vertical Z

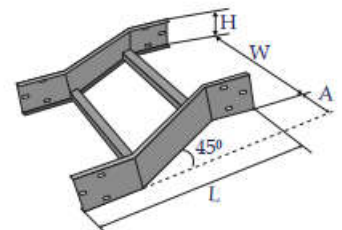

Co Z ngang phải
Right horizontal Z

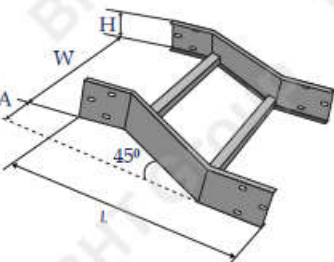

Co Z ngang trái
Left horizontal Z

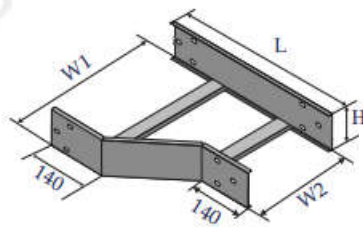

Co giảm phải
Right reducer

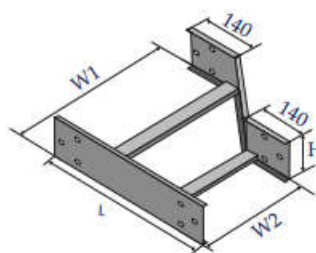

Co giảm trái
Left reducer

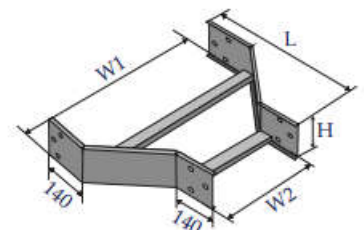

Co giảm giữa
Offset reducer

2.4 THÔNG SỐ KỸ THUẬT CO THANG CẤP

Cable ladder technical specifications



1. Vật liệu/Material

- Thép tấm tráng kẽm (JIS 3302).
- Thép tấm đen (cán nóng, cán nguội).
- Thép tấm không gỉ SS304, SS316.
- Pre galvanized steel sheet (JIS 3302).
- Mild steel sheet (hot rolled, cold rolled).
- Stainless steel sheet 304, 316.

2. Hoàn thiện sản phẩm/Finish

- Bề mặt tự nhiên của vật liệu đối với sản phẩm tôn tráng kẽm, thép không gỉ.
- Mạ nhúng nóng.
- Sơn tĩnh điện.
- Nature - protection for pre galvanized and stainless steel sheet.
- Hot dip galvanized - HDG.
- Power coated - PC

3. Độ dài tiêu chuẩn/Standard length

3.0m/thanh

3.0m/length

Tên hàng Item

Rộng x Cao x Dày W x H x T

L Cable ladder, light duty

1.0 thickness	50 x 50 x (1.0, 1.2)
1.2 thickness	75 x (50, 75) x (1.0, 1.2)
50mm high	100 x (50, 75, 100) x (1.0, 1.2)
75mm high	150 x (50, 75, 100) x (1.0, 1.2)
100mm high	200 x (50, 75, 100) x (1.0, 1.2)
	300 x (50, 75, 100) x (1.0, 1.2)

M Cable ladder, medium duty

1.5 thickness	100 x (75, 100) x 1.5
75mm high	200 x (75, 100) x 1.5
100mm high	300 x (75, 100) x 1.5
	400 x (75, 100) x 1.5
	500 x (75, 100) x 1.5
	600 x (75, 100) x 1.5
	700 x (75, 100) x 1.5
	800 x (75, 100) x 1.5

H Cable ladder, heavy duty

2.0 thickness	200 x (75, 100, 125, 150) x 2.0
75mm high	300 x (75, 100, 125, 150) x 2.0
100mm high	400 x (75, 100, 125, 150) x 2.0
125mm high	500 x (75, 100, 125, 150) x 2.0
150mm high	600 x (75, 100, 125, 150) x 2.0
	700 x (75, 100, 125, 150) x 2.0
	800 x (75, 100, 125, 150) x 2.0
	900 x (75, 100, 125, 150) x 2.0
	1000 x (75, 100, 125, 150) x 2.0

F Cable ladder, fittings

Bulong đầu dù cổ vuông - Mushroom head square neck bolt M8x12
 Long đên - Flat washer M8
 Con tán - Hex nut M8
 Miếng nối thang cáp - Ladder connector

• Note: Material thickness: 1, 1.2, 1.5, 2.0

Xin xác định vật liệu khi gửi yêu cầu/Please confirm material on your request

Tôn tráng kẽm
Pre galvanized steel

Mạ nhúng nóng - HDG
Hot dip galvanized - HDG

Sơn tĩnh điện - PC
Power coated - PC

Thép không gỉ
Stainless steel

3.1 THANH THẲNG KHAY CÁP

Cable tray straight

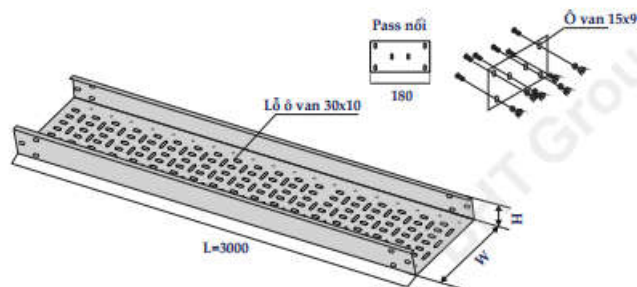
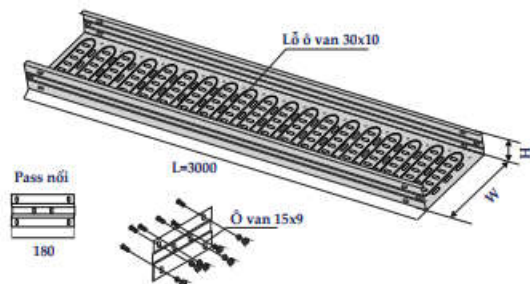

Dùng đường gân với khay:

- + W(100-150) x H(75,100): chỉ có gân cạnh (chiều H)
- + W(200 - 400) x H(75,100): có gân đáy (chiều W) và gân cạnh (chiều H).
- + W(200 - 400) x H(50): chỉ có gân đáy (chiều W).

Use ribs for trays:

- + W(100-150) x H(75,100): with side ribs only (along H).
- + W(200 - 400) x H(75,100): with bottom ribs (along W) and side ribs (along H).
- + W(200 - 400) x H(50): with bottom ribs only (along W).

Không dùng đường gân cho khay:

- + Vật liệu: inox, tole zam.
- + W < 100 hoặc W > 400.
- + Độ dày trên 2mm.

Do not use ribs for trays:

- + Material: stainless steel, zam-coated sheet.
- + W < 100 or W > 400.
- + Thickness over 2mm.

1. Vật liệu/Material

- Thép tấm tráng kẽm (JIS 3302).
- Thép tấm đen (cán nóng, cán nguội).
- Thép tấm không gỉ SS304, SS316.
- Pre galvanized steel sheet (JIS 3302).
- Mild steel sheet (hot rolled, cold rolled).
- Stainless steel sheet 304, 316.

2. Hoàn thiện sản phẩm/Finish

- Bề mặt tự nhiên của vật liệu đối với sản phẩm tôn tráng kẽm, thép không gỉ.
- Mạ nhúng nóng.
- Sơn tĩnh điện.
- Nature - protection for pre galvanized and stainless steel sheet.
- Hot dip galvanized - HDG.
- Power coated - PC

3. Độ dài tiêu chuẩn/Standard length

3.0m/thanh

3.0m/length

Tên hàng Item

Rộng x Cao x Dày W x H x T

L Cable tray, light duty

1.0 thickness	50 x 50 x 1.0 75 x (50, 75) x 1.0	100 x (50, 75, 100) x (1.0, 1.2)
1.2 thickness		150 x (50, 75, 100) x (1.0, 1.2)
50mm high		200 x (50, 75, 100) x (1.0, 1.2)
75mm high		300 x (50, 75, 100) x (1.0, 1.2)
100mm high		400 x (50, 75, 100) x (1.0, 1.2)

M Cable tray, medium duty

1.5 thickness 50mm high 75mm high 100mm high	100 x (50, 75, 100) x 1.5
	200 x (50, 75, 100) x 1.5
	300 x (50, 75, 100) x 1.5
	400 x (50, 75, 100) x 1.5
	500 x (50, 75, 100) x 1.5
	600 x (50, 75, 100) x 1.5
700 x (50, 75, 100) x 1.5	
800 x (50, 75, 100) x 1.5	

H Cable tray, heavy duty

2.0 thickness 75mm high 100mm high 125mm high 150mm high	200 x (75, 100, 125, 150) x 2.0
	300 x (75, 100, 125, 150) x 2.0
	400 x (75, 100, 125, 150) x 2.0
	500 x (75, 100, 125, 150) x 2.0
	600 x (75, 100, 125, 150) x 2.0
	700 x (75, 100, 125, 150) x 2.0
	800 x (75, 100, 125, 150) x 2.0
	900 x (75, 100, 125, 150) x 2.0
1000 x (75, 100, 125, 150) x 2.0	

F Cable tray, fittings

- Bulong đầu dẹt cổ vuông - Mushroom head square neck bolt M8x12
- Long dẹt - Flat washer M8
- Con tán - Hex nut M8
- Miếng nối thang cáp - Ladder connector

Note: Material thickness: 1, 1.2, 1.5, 2.0

Xin xác định vật liệu khi gửi yêu cầu/Please confirm material on your request

Tôn tráng kẽm
Pre galvanized steel

Mạ nhúng nóng - HDG
Hot dip galvanized - HDG

Sơn tĩnh điện - PC
Power coated - PC

Thép không gỉ
Stainless steel

3.2 CO KHAY CÁP GÂN CẠNH

Ribbed edges cable tray

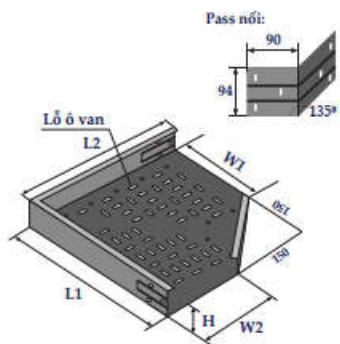

Co ngang 90°
Horizontal elbow 90°

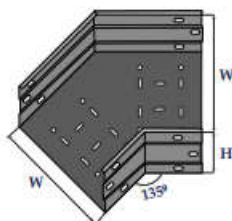

Co ngang 45°
Horizontal elbow 45°

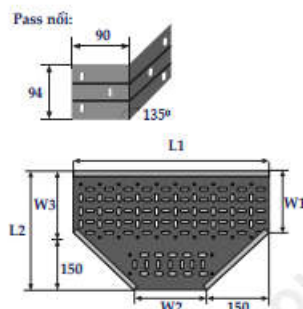

Co chữ T
Horizontal T

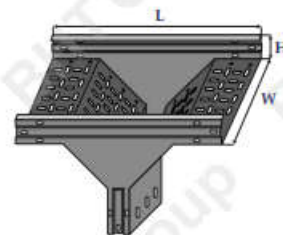

Co T đứng trục ngang
T shaped hinge horizontal

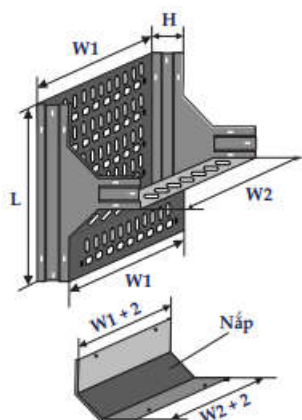

Co T đứng trục dọc
T shaped hinge vertical

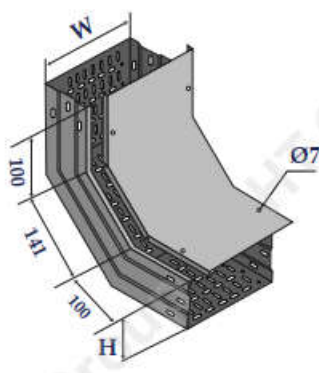

Co lên 90°
Internal riser 90°

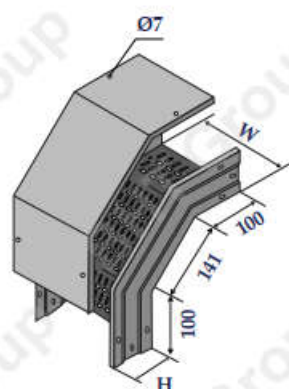

Co xuống 90°
External riser 90°

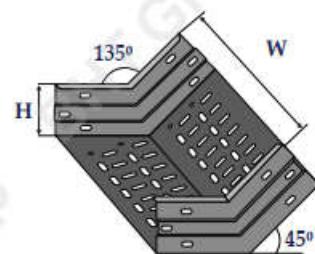

Co lên 45°
Internal riser 45°

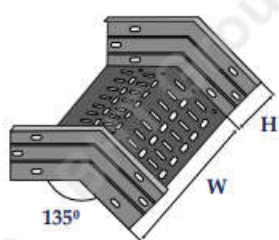

Co xuống 45°
External riser 45°

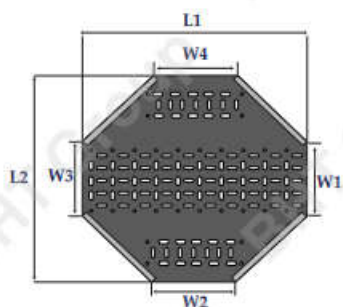

Co ngã tư
Horizontal cross

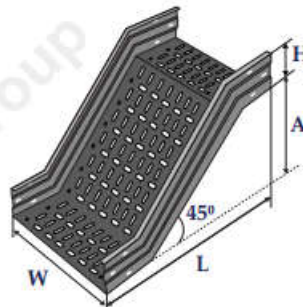

Co đứng Z
Vertical Z

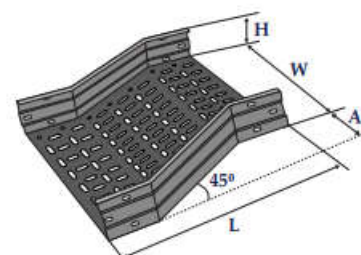

Co Z ngang phải
Right horizontal Z

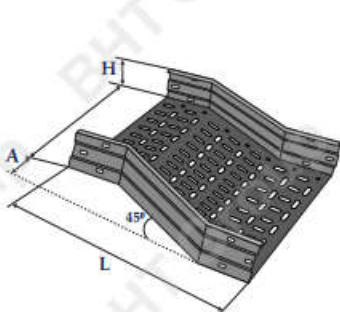

Co Z ngang trái
Left horizontal Z

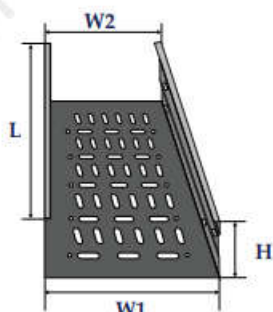

Co giảm phải
Right reducer

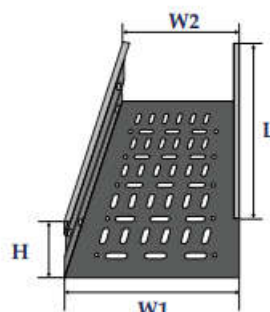

Co giảm trái
Left reducer

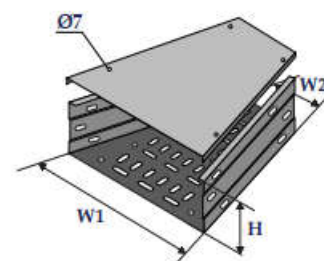

Co giảm giữa
Offset reducer

3.3 CO KHAY CÁP KHÔNG GÂN CẠNH

Cable tray without ribbed edges

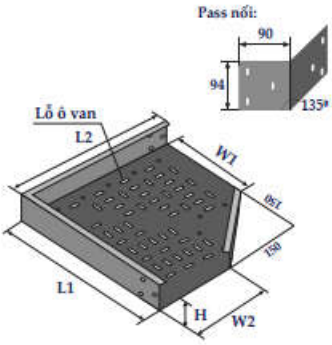

Co ngang 90°
Horizontal elbow 90°

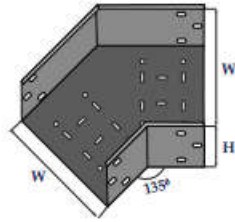

Co ngang 45°
Horizontal elbow 45°

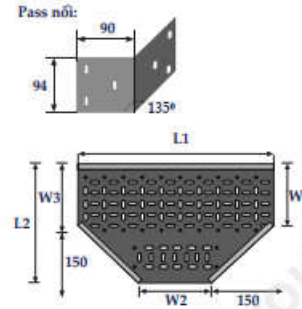

Co chữ T
Horizontal T

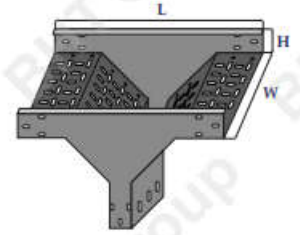

Co T đứng trục ngang
T shaped hinge horizontal

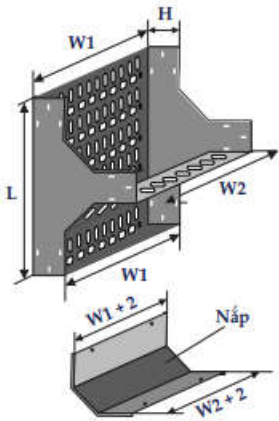

Co T đứng trục dọc
T shaped hinge vertical

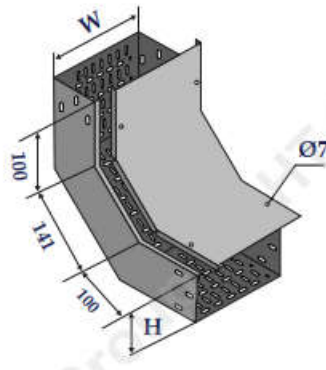

Co lên 90°
Internal riser 90°

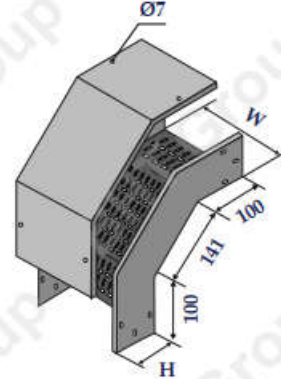

Co xuống 90°
External riser 90°

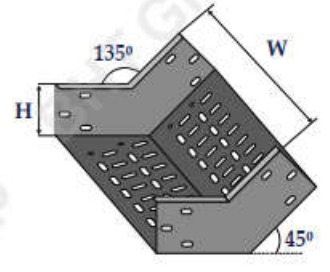

Co lên 45°
Internal riser 45°

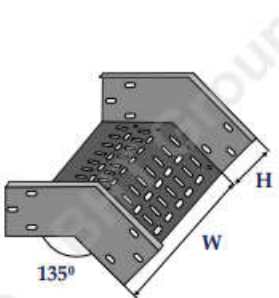

Co xuống 45°
External riser 45°

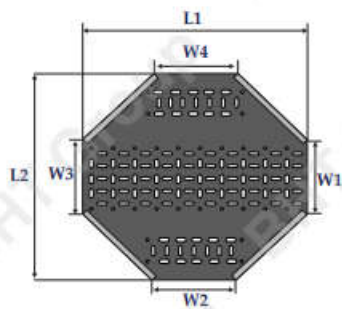

Co ngã tư
Horizontal cross

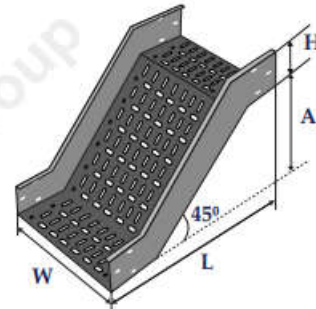

Co đứng Z
Vertical Z

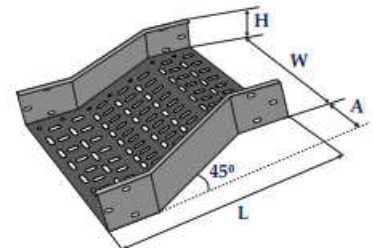

Co Z ngang phải
Right horizontal Z

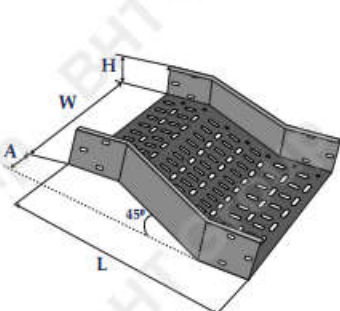

Co Z ngang trái
Left horizontal Z

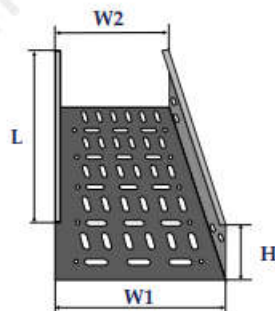

Co giảm phải
Right reducer

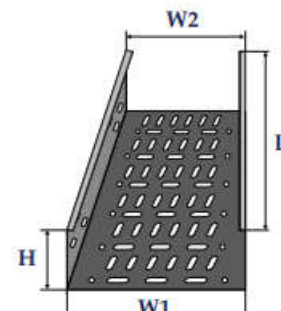

Co giảm trái
Left reducer

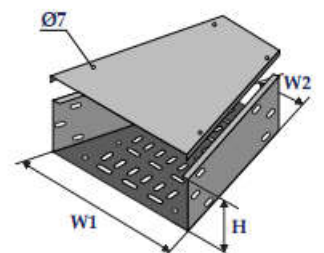

Co giảm giữa
Offset reducer

3.4 THÔNG SỐ KỸ THUẬT CO KHAY CÁP

Cable tray technical specifications



1. Vật liệu/Material

- Thép tấm tráng kẽm (JIS 3302).
- Thép tấm đen (cán nóng, cán nguội).
- Thép tấm không gỉ SS304, SS316.
- Pre galvanized steel sheet (JIS 3302).
- Mild steel sheet (hot rolled, cold rolled).
- Stainless steel sheet 304, 316.

2. Hoàn thiện sản phẩm/Finish

- Bề mặt tự nhiên của vật liệu đối với sản phẩm tôn tráng kẽm, thép không gỉ.
- Mạ nhúng nóng.
- Sơn tĩnh điện.
- Nature - protection for pre galvanized and stainless steel sheet.
- Hot dip galvanized - HDG.
- Power coated - PC

3. Độ dài tiêu chuẩn/Standard length

3.0m/thanh

3.0m/length

Tên hàng Item

Rộng x Cao x Dày W x H x T

L Cable tray, light duty

1.0 thickness	50 x 50 x 1.0 75 x (50, 75) x 1.0	100 x (50, 75, 100) x (1.0, 1.2)
1.2 thickness		150 x (50, 75, 100) x (1.0, 1.2)
50mm high		200 x (50, 75, 100) x (1.0, 1.2)
75mm high		300 x (50, 75, 100) x (1.0, 1.2)
100mm high		400 x (50, 75, 100) x (1.0, 1.2)

M Cable tray, medium duty

1.5 thickness	100 x (50, 75, 100) x 1.5
50mm high	200 x (50, 75, 100) x 1.5
75mm high	300 x (50, 75, 100) x 1.5
100mm high	400 x (50, 75, 100) x 1.5
	500 x (50, 75, 100) x 1.5
	600 x (50, 75, 100) x 1.5
	700 x (50, 75, 100) x 1.5
	800 x (50, 75, 100) x 1.5

H Cable tray, heavy duty

2.0 thickness	200 x (75, 100, 125, 150) x 2.0
75mm high	300 x (75, 100, 125, 150) x 2.0
100mm high	400 x (75, 100, 125, 150) x 2.0
125mm high	500 x (75, 100, 125, 150) x 2.0
150mm high	600 x (75, 100, 125, 150) x 2.0
	700 x (75, 100, 125, 150) x 2.0
	800 x (75, 100, 125, 150) x 2.0
	900 x (75, 100, 125, 150) x 2.0
	1000 x (75, 100, 125, 150) x 2.0

F Cable tray, fittings

- Bulong đầu dẹt cổ vuông - Mushroom head square neck bolt M8x12
- Long dẹt - Flat washer M8
- Con tán - Hex nut M8
- Miếng nối thang cáp - Ladder connector

• **Note: Material thickness: 1, 1.2, 1.5, 2.0**

Xin xác định vật liệu khi gửi yêu cầu/Please confirm material on your request

Tôn tráng kẽm
Pre galvanized steel

Mạ nhúng nóng - HDG
Hot dip galvanized - HDG

Sơn tĩnh điện - PC
Power coated - PC

Thép không gỉ
Stainless steel

4.1 THANH THẲNG MĂNG CÁP

Cable trunking straight

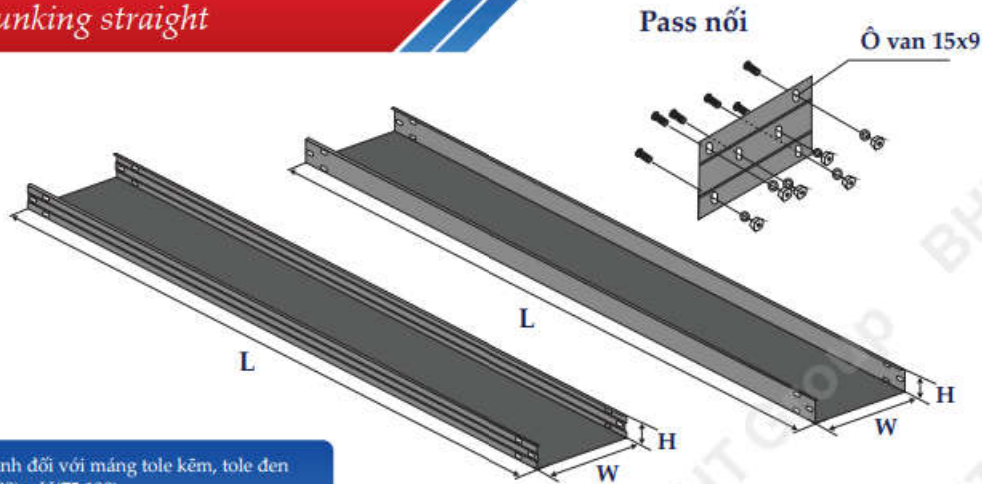

Áp dụng đường gân cạnh đối với máng tole kẽm, tole đen có kích thước W(100-400) x H(75,100).

Side ribs are applied only to galvanized steel, black steel trays with dimensions W(100-400) x H(75,100).

1. Vật liệu/Material

- Thép tấm tráng kẽm (JIS 3302).
- Thép tấm đen (cán nóng, cán nguội).
- Thép tấm không gỉ SS304, SS316.
- Pre galvanized steel sheet (JIS 3302).
- Mild steel sheet (hot rolled, cold rolled).
- Stainless steel sheet 304, 316.

2. Hoàn thiện sản phẩm/Finish

- Bề mặt tự nhiên của vật liệu đối với sản phẩm tôn tráng kẽm, thép không gỉ.
- Mạ nhúng nóng.
- Sơn tĩnh điện
- Nature - protection for pre galvanized and stainless steel sheet.
- Hot dip galvanized - HDG.
- Power coated - PC

3. Độ dài tiêu chuẩn/Standard length

3.0m/thanh

3.0m/length

Tên hàng Item

Rộng x Cao x Dày W x H x T

L Cable trunking, light duty

1.0 thickness	50 x 50 x 1.0 75 x (50, 75) x 1.0	100 x (50, 75, 100) x (1.0, 1.2)
1.2 thickness		150 x (50, 75, 100) x (1.0, 1.2)
50mm high		200 x (50, 75, 100) x (1.0, 1.2)
75mm high		300 x (50, 75, 100) x (1.0, 1.2)
100mm high		400 x (50, 75, 100) x (1.0, 1.2)

M Cable trunking, medium duty

1.5 thickness 50mm high 75mm high 100mm high	100 x (50, 75, 100) x 1.5
	200 x (50, 75, 100) x 1.5
	300 x (50, 75, 100) x 1.5
	400 x (50, 75, 100) x 1.5
	500 x (50, 75, 100) x 1.5
	600 x (50, 75, 100) x 1.5
700 x (50, 75, 100) x 1.5	
800 x (50, 75, 100) x 1.5	

H Cable trunking, heavy duty

2.0 thickness 75mm high 100mm high 125mm high 150mm high	200 x (75, 100, 125, 150) x 2.0
	300 x (75, 100, 125, 150) x 2.0
	400 x (75, 100, 125, 150) x 2.0
	500 x (75, 100, 125, 150) x 2.0
	600 x (75, 100, 125, 150) x 2.0
	700 x (75, 100, 125, 150) x 2.0
	800 x (75, 100, 125, 150) x 2.0
	900 x (75, 100, 125, 150) x 2.0
1000 x (75, 100, 125, 150) x 2.0	

F Cable trunking, fittings

Bulong đầu dù cổ vuông - Mushroom head square neck bolt M8 x12

Long dẹt - Flat washer M8

Con tán - Hex nut M8

Miếng nối thang cáp - Ladder connector

Note: Material thickness: 1, 1.2, 1.5, 2.0

Xin xác định vật liệu khi gửi yêu cầu/Please confirm material on your request

Tôn tráng kẽm
Pre galvanized steel

Mạ nhúng nóng - HDG
Hot dip galvanized - HDG

Sơn tĩnh điện - PC
Power coated - PC

Thép không gỉ
Stainless steel

4.2 CO MÁNG CÁP GÂN CẠNH

Ribbed edges cable trunking

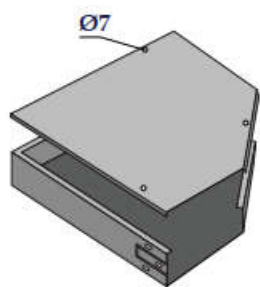

Co ngang 90°
Horizontal elbow 90°

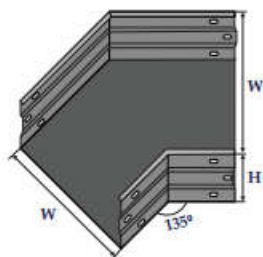

Co ngang 45°
Horizontal elbow 45°

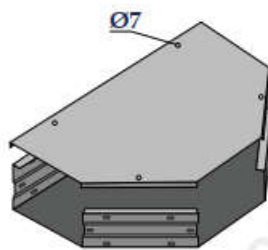

Co chữ T
Horizontal T

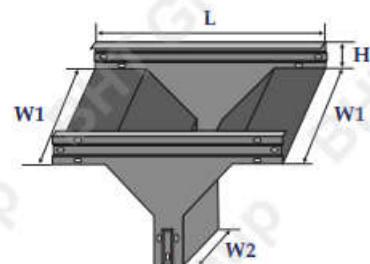

Co T đứng trục ngang
T shaped hinge horizontal

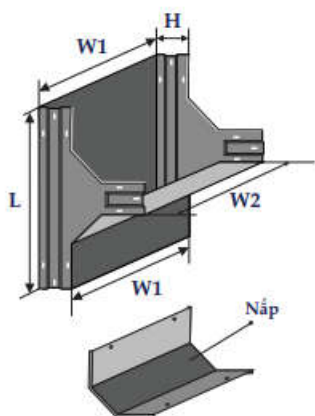

Co T đứng trục dọc
T shaped hinge vertical

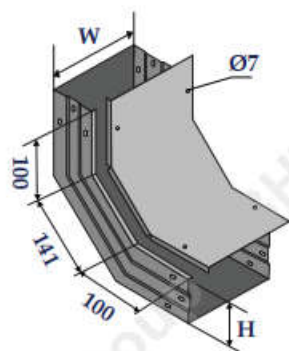

Co lên 90°
Internal riser 90°

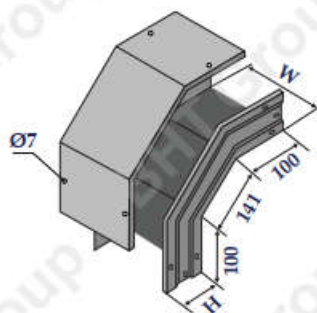

Co xuống 90°
External riser 90°

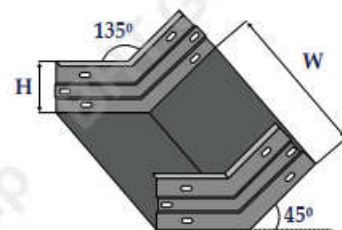

Co lên 45°
Internal riser 45°

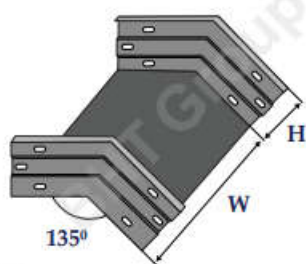

Co xuống 45°
External riser 45°

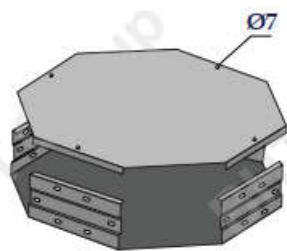

Co ngã tư
Horizontal cross

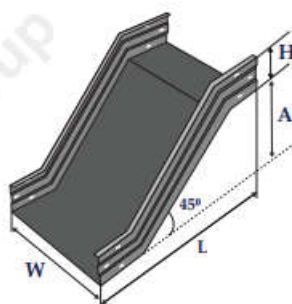

Co đứng Z
Vertical Z

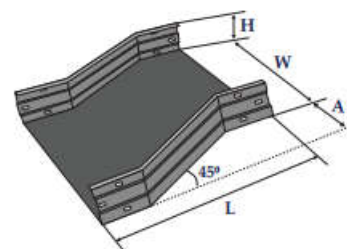

Co Z ngang phải
Right horizontal Z

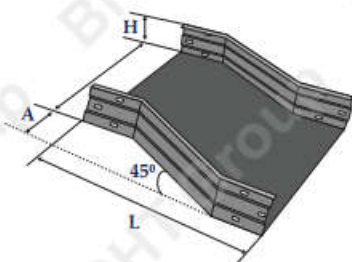

Co Z ngang trái
Left horizontal Z

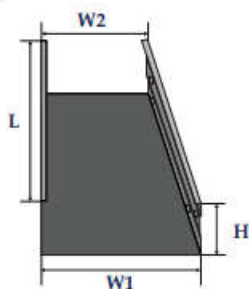

Co giảm phải
Right reducer

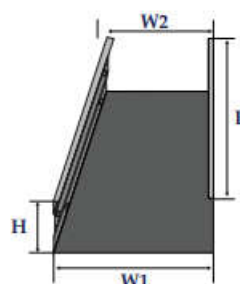

Co giảm trái
Left reducer

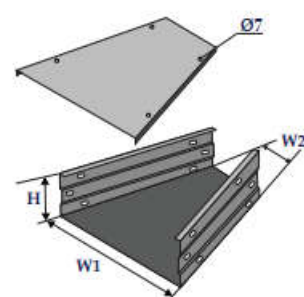

Co giảm giữa
Offset reducer

4.3 CO MÁNG CÁP KHÔNG GÂN CẠNH

Cable trunking without ribbed edges

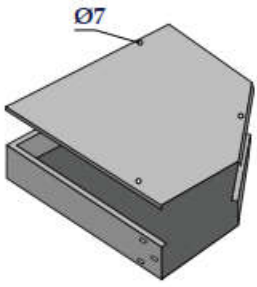

Co ngang 90°
Horizontal elbow 90°

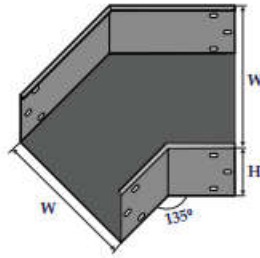

Co ngang 45°
Horizontal elbow 45°

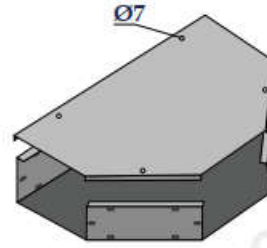

Co chữ T
Horizontal T

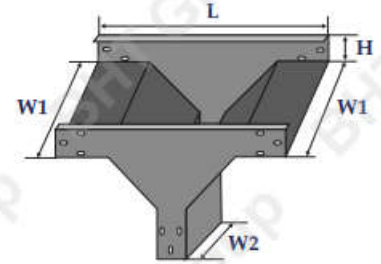

Co T đứng trục ngang
T shaped hinge horizontal

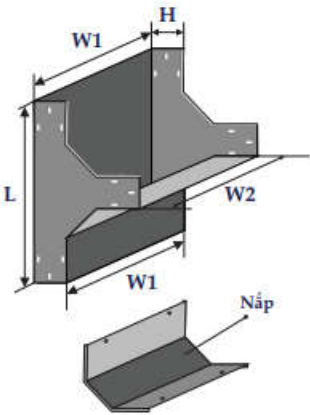

Co T đứng trục dọc
T shaped hinge vertical

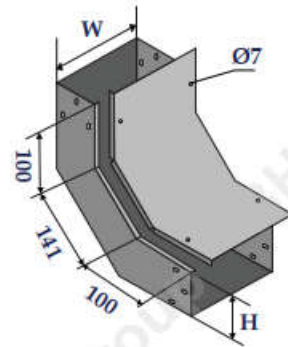

Co lên 90°
Internal riser 90°

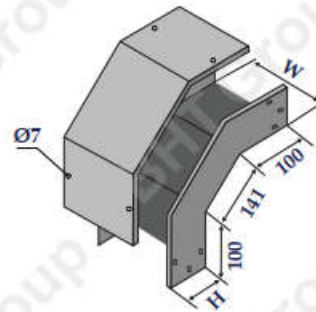

Co xuống 90°
External riser 90°

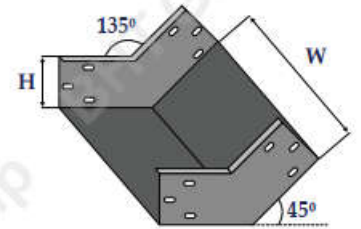

Co lên 45°
Internal riser 45°

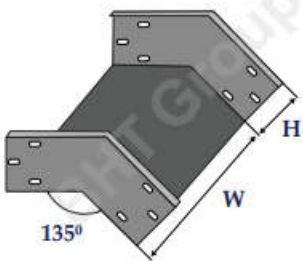

Co xuống 45°
External riser 45°

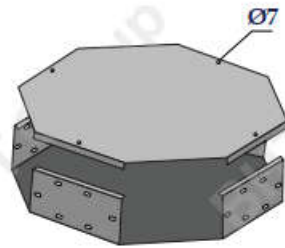

Co ngã tư
Horizontal cross



Co đứng Z
Vertical Z

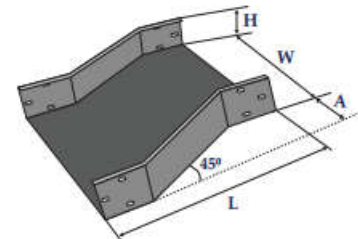

Co Z ngang phải
Right horizontal Z

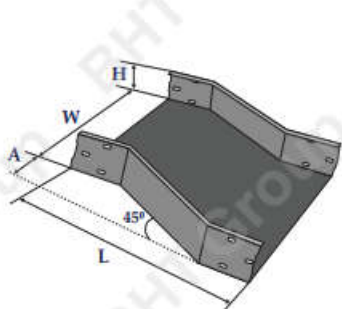

Co Z ngang trái
Left horizontal Z

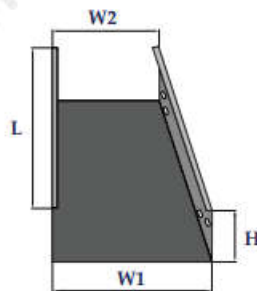

Co giảm phải
Right reducer

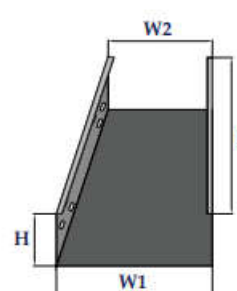

Co giảm trái
Left reducer

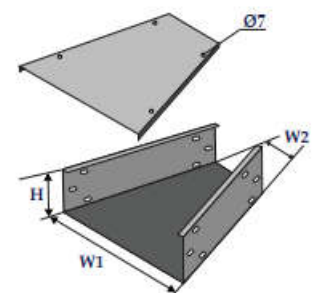

Co giảm giữa
Offset reducer

4.4 THÔNG SỐ KỸ THUẬT CO MÁNG CÁP

Cable trunking technical specifications



1. Vật liệu/Material

- Thép tấm tráng kẽm (JIS 3302).
- Thép tấm đen (cán nóng, cán nguội).
- Thép tấm không gỉ SS304, SS316.
- Pre galvanized steel sheet (JIS 3302).
- Mild steel sheet (hot rolled, cold rolled).
- Stainless steel sheet 304, 316.

2. Hoàn thiện sản phẩm/Finish

- Bề mặt tự nhiên của vật liệu đối với sản phẩm tôn tráng kẽm, thép không gỉ.
- Mạ nhúng nóng.
- Sơn tĩnh điện
- Nature - protection for pre galvanized and stainless steel sheet.
- Hot dip galvanized - HDG.
- Power coated - PC

3. Độ dài tiêu chuẩn/Standard length

3.0m/thanh

3.0m/length

Tên hàng Item

Rộng x Cao x Dày W x H x T

L Cable trunking, light duty

1.0 thickness	50 x 50 x 1.0 75 x (50, 75) x 1.0	100 x (50, 75, 100) x (1.0, 1.2)
1.2 thickness		150 x (50, 75, 100) x (1.0, 1.2)
50mm high		200 x (50, 75, 100) x (1.0, 1.2)
75mm high		300 x (50, 75, 100) x (1.0, 1.2)
100mm high		400 x (50, 75, 100) x (1.0, 1.2)

M Cable trunking, medium duty

1.5 thickness 50mm high 75mm high 100mm high	100 x (50, 75, 100) x 1.5
	200 x (50, 75, 100) x 1.5
	300 x (50, 75, 100) x 1.5
	400 x (50, 75, 100) x 1.5
	500 x (50, 75, 100) x 1.5
	600 x (50, 75, 100) x 1.5
	700 x (50, 75, 100) x 1.5
800 x (50, 75, 100) x 1.5	

H Cable trunking, heavy duty

2.0 thickness 75mm high 100mm high 125mm high 150mm high	200 x (75, 100, 125, 150) x 2.0
	300 x (75, 100, 125, 150) x 2.0
	400 x (75, 100, 125, 150) x 2.0
	500 x (75, 100, 125, 150) x 2.0
	600 x (75, 100, 125, 150) x 2.0
	700 x (75, 100, 125, 150) x 2.0
	800 x (75, 100, 125, 150) x 2.0
	900 x (75, 100, 125, 150) x 2.0
	1000 x (75, 100, 125, 150) x 2.0

F Cable trunking, fittings

Bulong đầu dù cổ vuông - Mushroom head square neck bolt M8x12
 Long đên - Flat washer M8
 Con tán - Hex nut M8
 Miếng nối thang cáp - Ladder connector

• Note: Material thickness: 1, 1.2, 1.5, 2.0

Xin xác định vật liệu khi gửi yêu cầu/Please confirm material on your request

Tôn tráng kẽm
Pre galvanized steel

Mạ nhúng nóng - HDG
Hot dip galvanized - HDG

Sơn tĩnh điện - PC
Power coated - PC

Thép không gỉ
Stainless steel

4.5 PHỤ KIỆN & THAM KHẢO
Accessories & Explore more

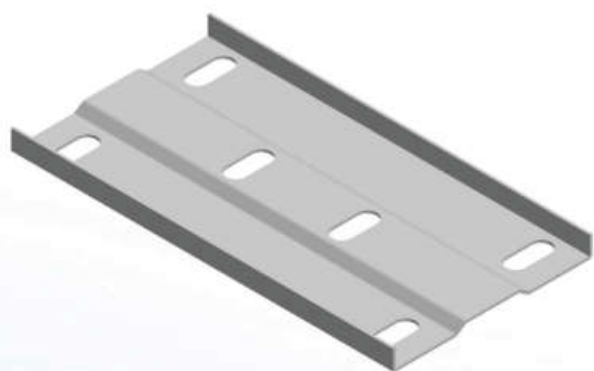

Pass nối chắn cạnh 10
10cm straight connector

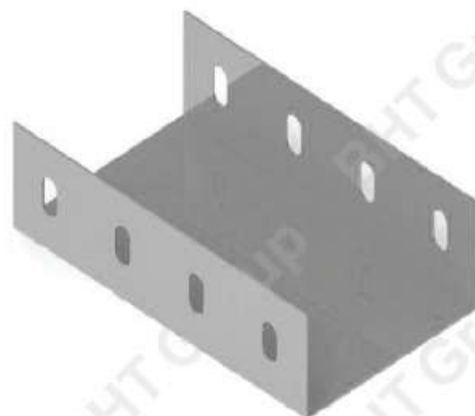

Pass nối chữ U
Connector U



Nối xoay ngang ngoài
Connector for outer
horizontal hinge



Nối xoay ngang trong
Connector for inner
horizontal hinge



Nối xoay đứng
Vertical Adjustable connector



Cùm Treo Lối Chắn U
Shackles hanging barrier U

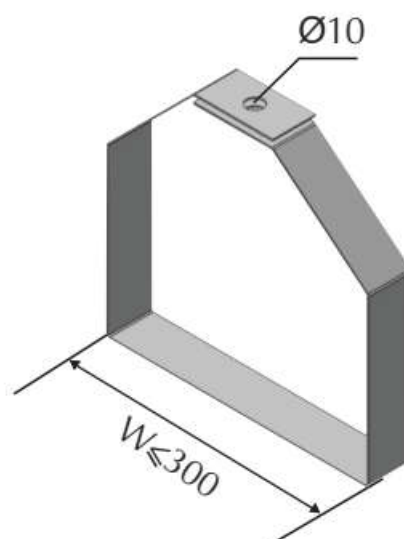

Cùm Treo Máng Cáp
Clevis hange

4.5 PHỤ KIỆN & THAM KHẢO

Accessories & Explore more

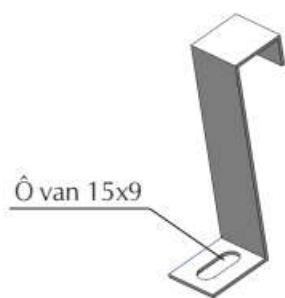

Pass kẹp Z
Hold down clamp



Pass kẹp Ω
Clamp



Giá đỡ chữ A
Support A



Giá đỡ chữ U
Support U

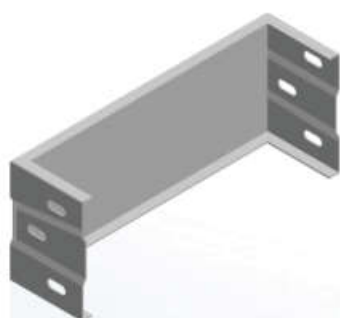

Chặn cuối
Endcap



Thanh ren - Bu lông, đai ốc
Threaded rod - Bulong



Dây tiếp địa
Ground wire

MÀU SẮC THÔNG DỤNG

Popular colors



Ral 7035 láng (nhấn)
RAL 7035 smooth (wrinkled)



Ral 7032 láng (nhấn)
RAL 7032 smooth (wrinkled)



Xanh dương
Blue



Màu cam
Orange



Màu đỏ
Red



Màu trắng
White

Note: Màu sắc sản phẩm được thay đổi theo yêu cầu khách hàng
Product color can be changed according to customer requirements.



TRỤ SỞ & NHÀ MÁY

Head Office & Factory

TRỤ SỞ CHÍNH TP. HỒ CHÍ MINH

1050/14 Đường Phạm Văn Đồng, KP 9, P. Hiệp Bình, TP.HCM.
 Phone: 0912 254 419
 Email: bht@bht.vn
 Liên hệ tư vấn, báo giá: sales@bht.vn

NHÀ MÁY BHT BÌNH DƯƠNG

Lô B2 - Đường số 3, KCN Tân Đông Hiệp B, P. Tân Đông Hiệp, TP. HCM.
 Phone: (0274) 377 6162 - 377 6163

NHÀ MÁY BHT HÓA AN

102/22A Huỳnh Mẫn Đạt, KP Bình Hóa, P. Biên Hòa, Đồng Nai.
 Phone: (0251) 2860 364

NHÀ MÁY BHT ĐÀ NẴNG

CCN Hòa Nhơn, Xã Bã Nà, TP. Đà Nẵng.
 Phone: (0236) 3727 656 - 3727 657

NHÀ MÁY BHT NAM HÀ

CCN Nam Hà 2, Đông Hà - Gia Huỳnh, Xã Trà Tân, Lâm Đồng.



CHI NHÁNH

Branches

CHI NHÁNH HÀ NỘI: số 25, ngõ 43/19 Lưu Hữu Phước, Cầu Diễn, Nam Từ Liêm, Hà Nội, Việt Nam.
 Phone: (024) 3200 1925

CHI NHÁNH NGHỆ AN: Toà nhà An Phát Complex, Đường 72M, TP. Vinh, Nghệ An, Việt Nam.
 Phone: 0982 858 290

CHI NHÁNH ĐÀ NẴNG: 234 Đường Nguyễn Trí Phương, P. Thanh Khê, TP. Đà Nẵng, Việt Nam.
 Phone: (0236) 3727 656 - 3727 677

CHI NHÁNH PHÚ YÊN: Căn hộ The Light Phú Yên số CH8-03, 220 Trần Hưng Đạo, P. Tuy Hòa, Đăk Lăk, Việt Nam.
 Phone: (0257) 3838 868

CHI NHÁNH NHA TRANG: STH23A-24 đường 1A KĐT Lê Hồng Phong 2, P. Nam Nha Trang, Khánh Hòa, Việt Nam.
 Phone: (0258) 3875 265

CHI NHÁNH BUÔN MA THUỘT: 191 Mai Hắc Đế, P. Buôn Ma Thuột, Đăk Lăk, Việt Nam.
 Phone: (0262) 3843 517

CHI NHÁNH BÌNH DƯƠNG: Lô B2 - Đường số 3, KCN Tân Đông Hiệp B, P. Tân Đông Hiệp, TP. HCM, Việt Nam.
 Phone: (0274) 3776 162

CHI NHÁNH ĐỒNG NAI: 102/22A Đường Huỳnh Mẫn Đạt, KP Bình Hóa, P. Biên Hòa, Đồng Nai, Việt Nam.
 Phone: (0251) 2860 364

CHI NHÁNH CẦN THƠ: 17 Đường Số 1, KDC Quân Báo, P. Bình Thủy, TP. Cần Thơ, Việt Nam.
 Phone: (0292) 384 6398

CHI NHÁNH PHÚ QUỐC: Villa Phong Nhà 3, Ấp Búng Gội, Cửa Dương, Phú Quốc, An Giang, Việt Nam.
 Phone: 0903 809 445